

smart JACK

SmartJack V4.0 Installation Manual



 **American**TM
garage door supply inc.
1-800-233-1487
carwashdoors.com

Please note: All Safeties Are Bypassed When In Hand Mode

10-20-2024

SmartJack V4.0 Installation

Table of Contents

	Page
Introduction/Mounting Area	3
Getting Started	4
Motor/Gearbox Installation	4-5
Home Limit Installation & Tuning	6
Control Box & Accessory Installation	7
Motor/Brake Wiring	8
Proximity Switch, Home Limit & Wall Station Wiring	9
Photoeye, Radio Control & Other Accessory Wiring	10
Pre-Start Up, Start Up, Quick Set-up, Test Operation	11
Basic Troubleshooting	12-13
Quick Setup Sheet/Wiring	14
Wiring Diagrams	15-18

WARNING!

Before any door is automated, the door must be level, balance and operate properly. Prior to activating this or any other operator system, verify by hand that the door operates smoothly and without fault.

SmartJack Operators are not designed to accommodate any door malfunction, installation or manufacturer's defect.

American Garage Door Supply recommends the use of proper safety entrapment protection in all situations to meet all required codes.

SmartJack V4.0 Installation

Introduction



The SmartJack V4.0 VFD Electric Garage Door Operator is easily installed and wired and consists of a high voltage motor/gearbox assembly with a low voltage proximity sensor acting as an encoder. The system is coupled with a high-quality control box that handles all of the programming and functionality of the product and the operator includes a 24V. 30mm proximity "home sensor" that is mounted to the wall for "close limit" calibration.

Wiring consists of high voltage wiring from the motor & brake (motor/gearbox) to the main control box and separate low voltage wiring for the proximity sensor, home sensor and accessories

Numerous control devices can be wired in as inputs for open/close & stop functionality of the product.

Four outputs are available for signalling when the door is fully open, closed, in motion, or when the door is closing.

These outputs can be used to control other devices such as: warning horns or lights, monitors or door interlocks or other mechanisms including vehicle wash or HVAC equipment.

WARNING!

Automated doors can be dangerous if used unsafely or improperly installed. If operated in these conditions, automated doors may cause bodily harm or death.

Motor/Gearbox Mounting Area

The SmartJack Operator motor/gearbox must be mounted to a solid, well-prepared surface that is adequate to handle the weight of the operator and accommodate stresses of continual operation of the door size and weight without movement.



SmartJack V4.0 Installation

Getting Started

Determine where you will be mounting the operator.

Typically, the SmartJack Operator has been ordered for the correct mounting side of the door prior to deliver. If the operator was not properly ordered and needs to be used for the other side of the door, it can be changed easily in the field. For instructions, please see our video on our You Tube channel at <https://www.youtube.com/watch?v=2PVeWNUHGYA>.

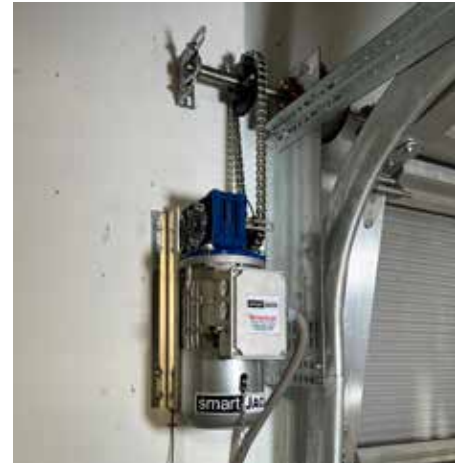

Left Hand Shown

Installing the Motor/Gearbox Unit

Step 1

Slide the door sprocket on the door shaft (Figure 1). Position the set screws so they are easily accessible for service.

Leave enough room for mounting a bearing plate on the end of the shaft for support later.

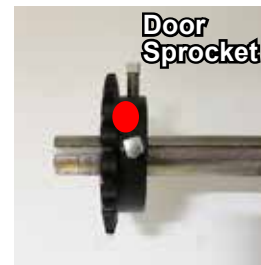

Figure 1

Step 2

Close the door and lock it down for safety.

Step 3

Assemble the chain by adding the master link onto the supplied #50 chain. When done, place the chain on the door sprocket as pictured. (figure 2)

Tip- When the installation is complete, the center of the operator drive shaft dimension to the center of the door shaft should equal 12"-16".



Figure 2

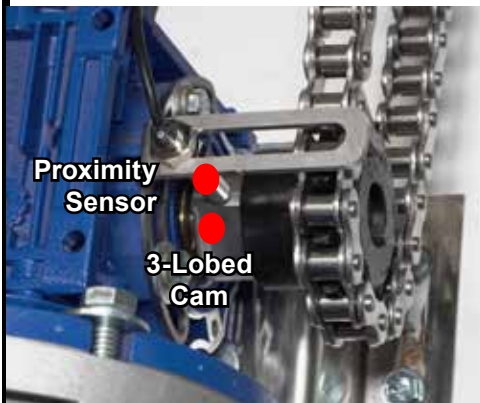

Before continuing.....

The proximity sensor is mounted near the drive sprocket located on the side of the SmartJack gearbox.

First, check to see if it has loosened with handling or shipping.

Before moving forward make sure the end of the proximity sensor clears the round portion (high point) of the 3-lobed cam by approximately 1/16 of an inch or less.

The proximity sensor and bracket bolts should be tightened securely so they will not move vibrate or move during operation.

SmartJack V4.0 Installation

Step 4

Hang the motor/gearbox assembly on the chain as pictured (figure 3)
Position the unit so the operator is level and plumb and the chain is aligned properly before securing the unit to wall (figures 4-6).

Important!

When positioning the operator for final mounting to the wall, the chain should be snug and plumb (figure 4).

Use the gearbox housing as your reference to ensure the unit is mounted level and plumb. (figures 5-6)

DO NOT use the stainless base plate for reference.



Figure 3



Figure 4



Figure 5



Figure 6

When initially fastening unit to wall, place the fasteners/lags in the center of the vertical slotted hole. This will allow you to make adjustments to the chain tension. (figure 8)

Once the operator is positioned properly, relocate or add the fasteners/lags to the bottom of the slotted holes to prevent the unit from moving up from continual operation. (figure 9)

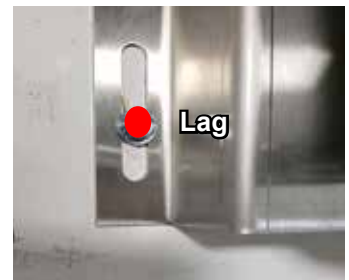

Figure 8



Manual Disconnect Installation

The manual disconnect chain is attached to the brake lever located on the front of the motor/fan assembly. (figure 9)

After installing the motor/gearbox, remove the packaging and allow the chain to drop.

Then, mount the chainkeeper bracket on the wall with lags as shown.

Make sure the bracket will hold the disconnect chain in place while holding the brake lever in the manual (down) position.

When the disconnect is disengaged, the door should operate manually.

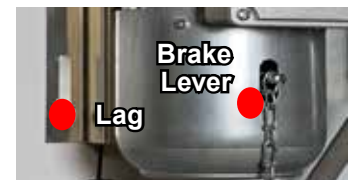

Figure 9



Figure 7

A bearing plate should be installed to support the torsion shaft once the operator has been installed (figure 7). This prevents the shaft from deflecting causing chain issues.



SmartJack V4.0 Installation

Home Limit Sensor Installation

The home limit proximity sensor sends a signal to the PLC and indicates that the door is fully-closed and in it's final resting position or close limit. (See figure 10)

This proximity switch and target assembly is typically mounted between 6 to 7 feet from the floor or high enough to prevent tampering. The sensor is triggered when the target bracket mounted on the door passes within 1/2" to 3/4" from the face of the sensor.

Step 1

Assemble the Home Limit Target Bracket and Home Limit Door Bracket using the supplied track bolts and nuts. (figure 11)

Step 2

****Mount the assembly from Step 1 on the end stile of the door with the self-drilling screws provided**

It is recommended to center the bracket on end stile so that the target will be in alignment with the proximity sensor installed in the next steps..

Step 3

Assemble the 30 mm proximity sensor to the wall mounting bracket. Next, install the wiring harness to the back of the proximity sensor and tighten. Install the sensor/wall bracket assembly to the wall using the supplied lags. (figure 12).

Ensure the proximity sensor is properly aligned with the target bracket when the door is fully closed.

****Important!**

Position the wall bracket with proximity sensor and target bracket so that when the door is fully closed, the door target bracket will align with the sensor and passes within 1/2" to 3/4" of the target.



Figure 10

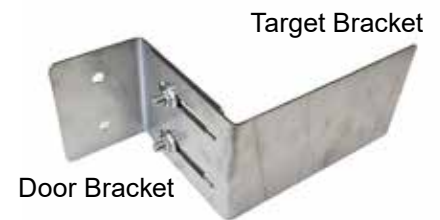

Figure 11

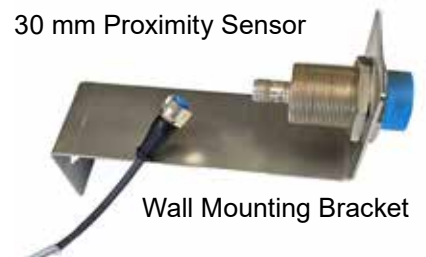

Figure 12



Figure 13



Fine Tuning...

The proximity sensor position can be fine-tuned after the SmartJack is completely installed and wiring is complete. This will ensure the sensor detects at the exact moment the door reaches the closed position.

To fine tune the sensor, position the door bracket assembly w/ target bracket and/or the sensor/wall bracket assembly so that the proximity sensor detects the target at the fully closed position of the door.

When powered up, the sensor led indicator on the back of the sensor lights up when detection occurs.

SmartJack V4.0 Installation

Control Box Installation & Accessories

Most SmartJack operators models use a high quality NEMA 4X control box to handle tougher conditions and can be mounted just about anywhere.

Whenever possible, we recommended to mount the control box in a dry, secure, but accessible area.

Note: Some applications may require mounting the control box in a out of reach area to prevent unwanted tampering.



Mounting Area

The SmartJack Control Box should be mounted to a surface that will handle the weight of the Control Box and allow appropriate distances for electrical connections and meeting local codes.

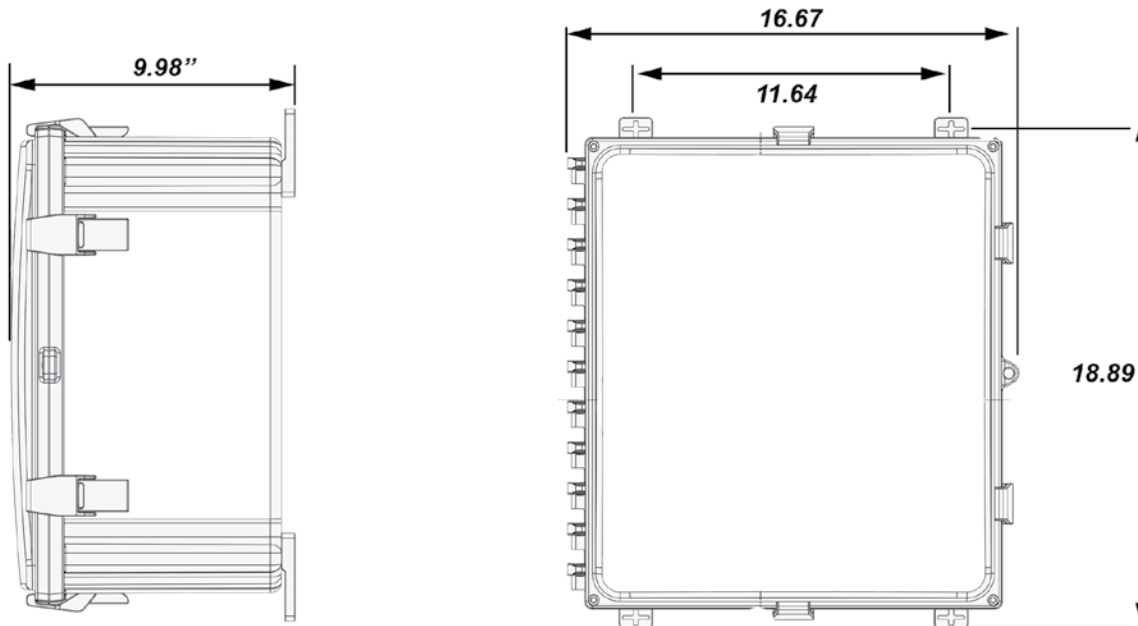

Mounting the Control Box

Install the control box where desired using the supplied mounting tabs and adequate fasteners. Ensure the control box is mounted plumb and level. Follow all applicable electrical and building codes.

WARNING!

Warranty will be voided if holes are drilled in the top of the control box or if moisture is allowed into the control box.

Accessories

Assemble and install any accessories such as: electric edges, photoeyes or light curtains, control stations, motion detectors, ground loops or other devices according to the individual product manufacturers instructions.



SmartJack V4.0 Installation

Wiring The SmartJack

Wiring Smartjack's operators is simple, just follow the wiring diagram and terminate all of your necessary connections to the push-in terminal block. It is clearly labelled for easy identification.

Important!

- Never run the motor/brake high voltage wires with low voltage wires such as: the proximity switch, home limit switch, photoeyes, etc.
- Always use liquid tight connections and flexible conduit.
- Protect connection points in NEMA-4X junction boxes
- Heat shrink or use other moisture resistive wire connections
- All conduit should be positioned to run "up" to the motor/gearbox assembly or control box rather than "down". Conduit running down into either may allow moisture to damage the internal components voiding the warranty.
- Holes drilled in the top of the control box will also void the warranty
- Identify and mark all wires to ensure correct connections.
- Secure or zip-tie all loose wire cables

Motor/Brake Wiring

The Smartjack's motor and brake are pre-wired, sealed with liquid tight connectors and includes approximately 3 feet of flexible conduit and wire. This allows for easy connection to a separate NEMA-4X junction box.

From that separate junction box, run 6- 14 GA AWG wires directly to the Control Box (3- Motor, 2- Brake and 1- Ground)

Note: These wires can be run together in the same conduit.



Inside Control Box



Push-in Terminal Block



Pre-wired for easy identification



Internal view of sealed Motor/Brake Junction Box

Motor/Brake Connections

<u>Motor</u>	<u>Control Box</u>
T1	T1
T2	T2
T3	T3
Ground Screw	GND
<u>Brake</u>	<u>Control Box</u>
1	See Wiring Diagram for Specific Volt./Ph.
2	See Wiring Diagram for Specific Volt./Ph.



SmartJack V4.0 Installation

Proximity Sensor Wiring

Locate the Proximity Sensor located on the motor drive gear next to the gearbox. Wire directly to the Control Box. See wiring requirements below.

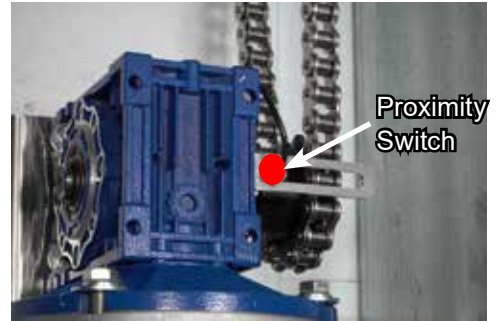

Proximity Sensor Connections

Proximity (Color)	Control Box
Brown	24H
Blue	24N
Black	350

Wire Requirements

Use 14-18 AWG wire or other suitable formats following local codes. Use wire sizes and formats to accommodate the length of wire run from the motor/gear assembly to the Control Box.

Home Limit Proximity Sensor Wiring

Wire the Home Limit Switch previously installed on the door section and wall to the Control Box



Home Limit Switch Connections

Home Switch (Color)	Control Box
Brown	24H
Blue	24N
Black	330

-Warning-

NEVER run Proximity Sensor, Home Limit Switch, Photoeyes or any other low voltage wires in the same conduit as high voltage wiring (motor/brake). It will cause signal interference.

Control Station Wiring

For wiring 3 button wall stations, keyswitches and other controls

*4-wire setup ONLY applicable with one remote pushbutton station.

**5-wire setup preferred to allow for more than one remote pushbutton station to run stop buttons in series from station to station

3- Button Stations

(*4-wire Configuration)

Common	260
Close	240
Open	220
Stop	261

Remove Jumper on 260 and 261

3- Button Stations

(*5-wire Configuration)

Open/Close Common	24H
Close	240
Open	220
Stop Common	260
Stop	261

Remove Jumper on 260 and 261



Use 14-18 AWG wire



SmartJack V4.0 Installation

Telco Photoeye Wiring

SmartJack Operators include a pre-wired 11-pin amplifier base for Telco photoeyes installed right in the control box (figures 13-14).

Just wire in the transmitter and receiver eyes to the base and plug in the amplifier.

Photoelectrics and other signalling devices must use DC amperage.

Telco Wiring Instructions

Transmitter (LT)- Eyes- Connect Black to #7 on the Base and Red to #5 on the Base.

Receiver (LR)- Eyes- Connect the Yellow to #6 and the non-shielded to #8 on the base.

Amplifier- Plug-in to the 11-pin base.

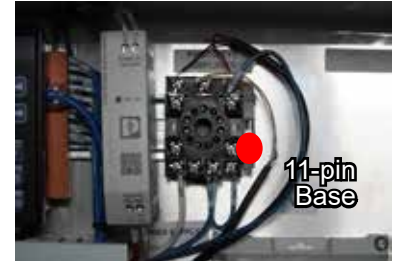
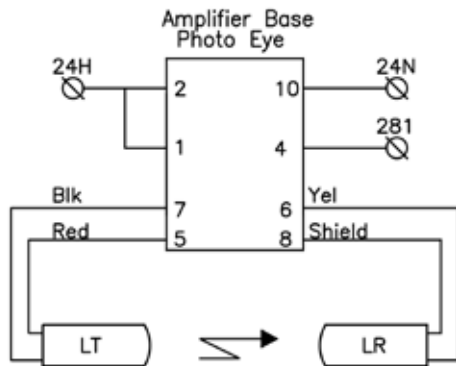

Figure 13



Figure 14

Radio Control Wiring

Radio Control Receivers are easily wired to SmartJack Operators.

850LM & MVP-RE Shown

850LM

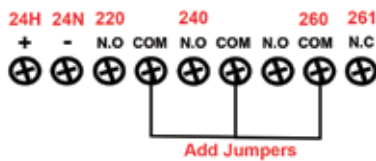

MVP-RE

Receiver (Color) Control Box

Red (24V)	24H
White (24N)	24N
Orange 1 (Open)	220
Black 1 (Close)	240
Grey 1 (Stop)	261
Grey 2 (Jumper)	260

Jumpers Required

Orange 2 to Black 2
Black 2 to Grey 2



Other Photoelectrics & Accessories

Numerous other safety and entry devices and accessories such as: other photoelectric systems, loop detectors, motion detectors, entry systems and many others can be integrated with the SmartJack.

Refer to the wiring diagram or contact your company representative for specific details.

SmartJack V4.0 Installation

Pre-Start-Up:

Once the SmartJack has been properly installed and wired, the motor direction should be tested to make sure the motor is wired properly.

Important

To test the direction, you must first remove the roller chain.

Test the motor direction by using the open/close push buttons on the face of the control box (when powered up) to run the operator.

If the operator drive shaft rotates in the opposite direction of the command given (open/close), swap the T1 or T2 wires coming from the motor.

When complete reattached the roller chain and ensure the door is in the closed (down) position and unlocked before continuing

Start-Up:

Step 1

Turn the "Hand/Auto mode" switch on the front of the control box to the "Auto" Mode setting

Step 2

Open the Control Box cover and locate the PLC Display inside the box

Step 3

Turn the main power on via the primary power switch or breaker, you will see the Control Box power up and the display turn on.

Step 4

On the controller (top left Corner in the box, Press "1" for settings. You'll see the **"Quick Set-up Mode"**. Follow the simple instructions on the display to set the doors open and close limits.

Quick Set-up Mode

At the displays' command, run the operator in the up direction until you have reached the final "Open" position. You will have to press the open button on the face of the Control Box to do this. When done, press the "enter" key. The screen should read "Set-up Completed". At that point, Press "enter" and then press "2" to exit..

Test Operation

Before testing and finalizing the installation see the **SmartJack Door Controller Programming & Setup Manual** for important programming, safety and setup information.



PLC Display



SmartJack V4.0 Installation

Basic Troubleshooting

There are a number of ways to troubleshoot issues that prevent the SmartJack from operating. Here are a few common issues, methods and tools that will help you identify and correct potential issues.

The PLC display or the VFD inverter are great tools to use when troubleshooting. Here are some basics, but if you are unable to correct your issue, please feel free to contact our technical department.

Proximity Sensor Issues-

When the Smartjack is wired properly, powered-up and running, the proximity switch at the motor/gearbox should be energized.

When working properly, the led indicator on the proximity sensor should illuminate when the 3-lobed cam on the shaft is closest to the sensor during the operators travel. If it is not, check the wiring to the sensor and make sure you have good terminations in the control box.

The 12 input (I-12) as displayed on the PLC, shows the activity of the proximity sensor. When working properly the input indicator darkens when the sensor is closest to the 3-lobed cam. When operating properly, the display should show a rapid light/dark as the Smartjack is operating.

Home Limit Sensor Issues

The Home Limit Sensor must operate properly for you to program or operate the SmartJack.

To verify the Home Limit Sensor is detecting properly, find the input number 10 (I-10) in the PLC display. If I-10 is dark, the switch is detecting the target bracket (the door should be fully-closed). When the sensor is not detecting, (Door in motion or open) the indicator will be white or clear. If the home sensor is not working, please check the wiring, position of the brackets and proximity switch and terminations in the control box.

Basic Input issues

To determine if an accessory such as: a pushbutton, motion detector, safety eye or other device is signalling the operator, please see the input for that device in the SmartJack Programming Manual and check to see if the input is energized (dark circle) or if it is not (white or clear circle).

Basic Motor Issues

A number of motor related issues can be found by observing the display on the VFD inverter. For these types of errors, please see our Smartjack trouble shooting guide.

SmartJack V4.0 Installation

Motor Rectifier Issues

If the opener will not open or close and an audible click can no longer be heard when the opener was commanded to open or close. The opener could have a rectifier that is not working properly. To see if rectifier is the problem, meter the two wires coming into and out of the rectifier located in the wiring box on the motor. The two leads coming from the main control box on the side of the rectifier is the incoming voltage and should meter 200VAC (when the opener gets an open or close command).

If it doesn't meter 200VAC, there is a problem with the relay in the main control cabinet.

If there was 200VAC above, then check the other wires (with command) that go out of the rectifier to the armature (inside wires). This should meter 200VDC. If they do not, the rectifier needs replacement.

Brake Failure

Check to see if you are getting 220 V across the brake leads at at the motor- That is the 2 terminals with the alternating current symbols or sideways "S" (Outside Terminals (some units they are labeled 1 & 2.-V3 units)

If you are getting voltage, You could have a bad rectifier. **Motor Issues**

Disconnect the motor from the terminal block where field wired, turn the power on and see if the breaker trips.

Ohm each leg to the ground of that motor to see if it is shorted internally

Run it without the motor disconnected to see if there is a VFD outputs voltage.

PLC Reset- (Run versus Idle)

At times, due to a brown-out or interruption in power, the PLC may go into an "Idle mode".

This will cause the opener to show errors that seem to have been corrected or show inputs that are not consistent with the actual situation.

Similar to an old stick shift truck that slips into neutral by accident, the unit will not operate properly until it gets put back into drive.

Here's how to identify the mode it is in and how to correct it if it is incorrect.

- Go to LED Screen on the PLC and hit both "Up" and "Down" arrow at the same time to get the main screen.
- Toggle with arrows to the "View Status" screen and press enter.
- Toggle with arrows to the "Mode", screen, press enter.

If the "Mode" shows "RUN" on the screen, your PLC is set up correctly. Exit out of the screen.

If the "Mode" shows "Idle" on the screen, your PLC needs to be changed to "Run". To do this...

Press "Enter", toggle with arrows to "Run". Press "Enter" to accept.

Exit out by pressing the "F2" or "escape" button.

Your PLC should now be in "Run" mode.

If you want to reset the date and other parameters hit the both the up and down key at the same time. You will get another menu look from there.....



SmartJack V4.0 Installation

Quick Set-Up Sheet

Incoming Power

- 1 L1 Hook Up To Top Side Of Disconnect
- 2 L2 Hook Up To Top Side Of Disconnect
- 3 L3 Hook Up To Top Side Of Disconnect
- 4 Gnd Hook To Ground Lug

Motor Wiring

- 1 T1 Terminal Block
- 2 T2 Terminal Block
- 3 T3 Terminal Block
- 4 Gnd Terminal Block

Brake Wiring

- 115-240 VAC 1 Ph./ 3Ph.
- 90 Terminal Block
- N/L2 Terminal Block
- 480 VAC 3 Ph.
- 111 Terminal Block
- 120 Terminal Block

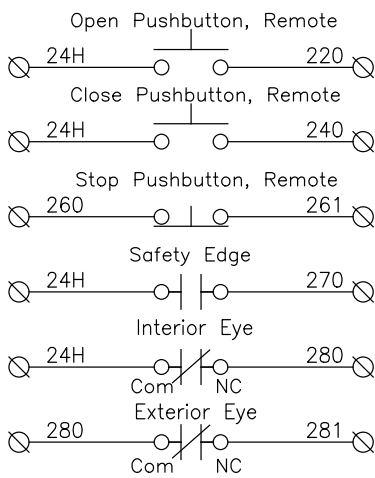

Remove Jumper If Used

See complete wiring diagram for detailed schematic.
Red lines on detailed schematic show wiring to be performed in the field.

Add Jumper If NOT Used

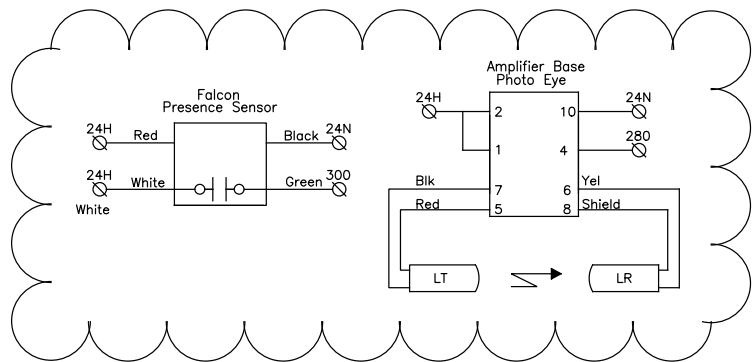
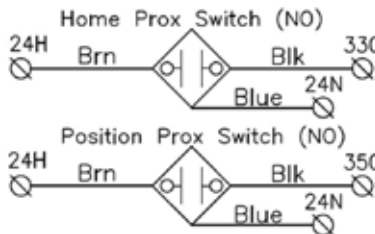
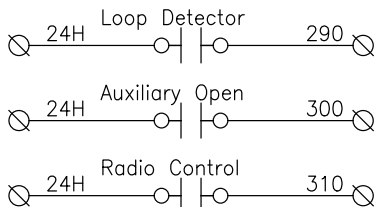

DRAWING TITLE		smart JACK		American garage door supply inc.	
PROJECT		Quick Hookup		1225 Industrial Park Dr SE. Bemidji, MN 56601	
LOCATION		C.W. Automation Inc.		1-800-233-1487 Ph. (218) 751-6551 Fax	
DISTRIBUTOR		Drawing Tolerances Unless Otherwise Specified:		DN BY CW 07.07.22	
NO.		REVISION		CK BY	
BY		DATE		DRAWING NUMBER	
ANGLES		SCALE		SmartJack	



SmartJack V4.0 Installation

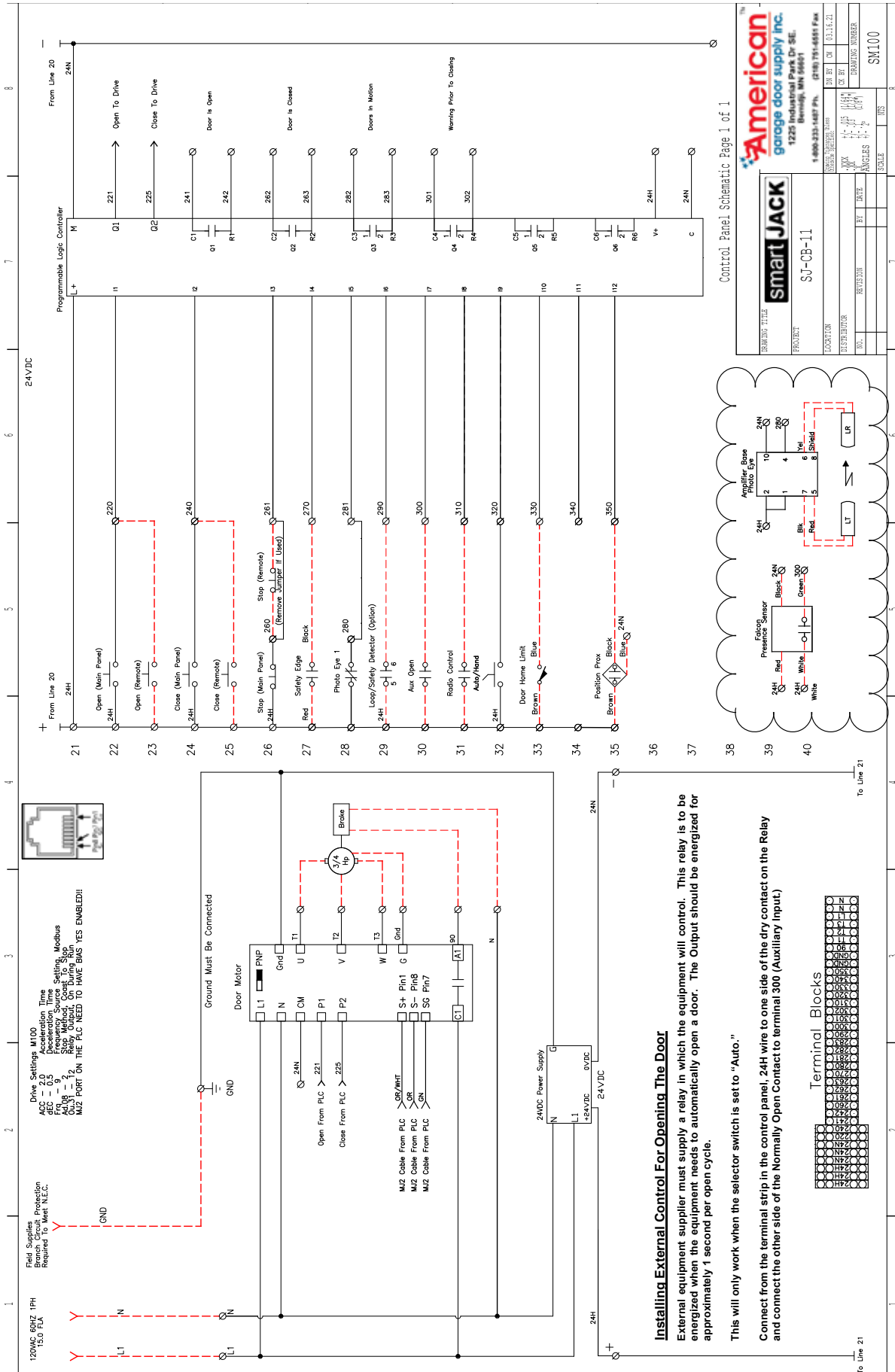

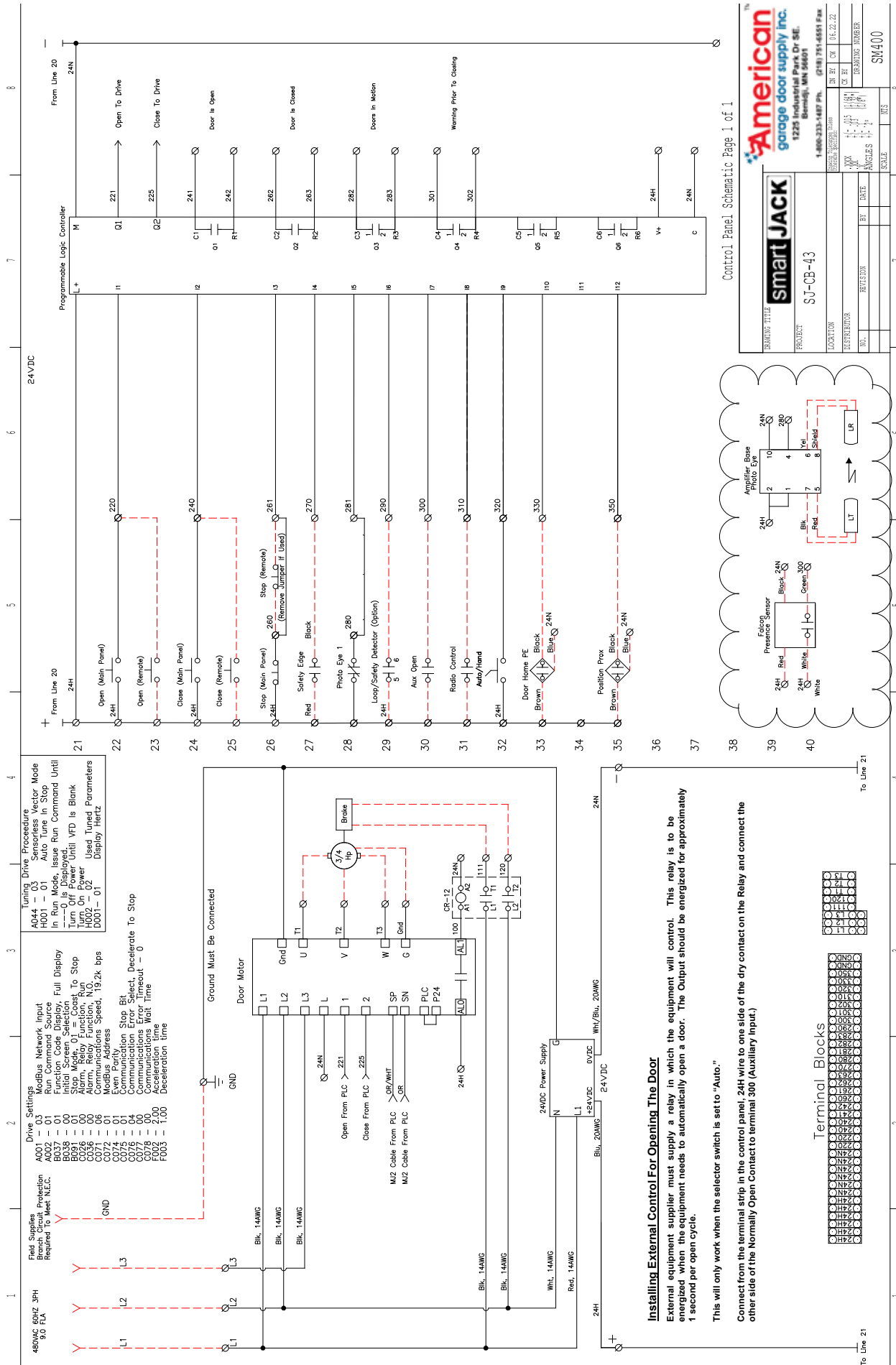

Field Supplies
488VAC 50HZ 3PH
9.0 FLA
Branch Circuit
Required to Meet N.E.C.
GND

Drive Settings
A001 - 03 ModBus Network Input
A002 - 01 Run Command Source
B038 - 00 Initial Screen Selection
B039 - 01 Full Display
C001 - 01 Stop Mode, 01 = Coast To Stop
C002 - 00 Alarm, Relay Function, NO
C003 - 00 Alarm, Relay Function, NC
C004 - 08 Communications Speed, 19.2k bps
C005 - 01 ModBus Address
C006 - 01 ModBus Address
C007 - 01 ModBus Address
C008 - 01 ModBus Address
C009 - 01 ModBus Address
C010 - 01 ModBus Address
C011 - 01 ModBus Address
C012 - 01 ModBus Address
C013 - 01 ModBus Address
C014 - 01 ModBus Address
C015 - 01 ModBus Address
C016 - 04 Communications Error Timeout - 0
C017 - 00 Communications Error Timeout - 0
C018 - 00 Communications Error Timeout - 0
F002 - 2.100 Acceleration time
F003 - 1.100 Deceleration time

Tuning Drive Procedure
A044 - 01 In Run Mode, Issue Run Command Until
H001 - 01 Auto Tune In Stop
Turn Off Power Until VFD is Blank
H002 - 01 Auto Tune In Run
H003 - 01 Auto Tune In Run
D001 - 01 Used Tuned Parameters

Ground Must Be Connected

Installing External Control For Opening The Door
External equipment supplier must supply a relay in which the equipment will control. This relay is to be energized when the equipment needs to automatically open a door. The Output should be energized for approximately 1 second per open cycle.
This will only work when the selector switch is set to "Auto."
Connect from the terminal strip in the control panel, 244H wire to one side of the dry contact on the Relay and connect the other side of the Normally Open Contact to terminal 300 (Auxiliary Input)



Control Panel Schematic Page 1 of 1

smart JACK

PROJECT: S-J-CB-43

LOCATIONS: []

DISTRIBUTOR: []

NO.: []

REVISION: []

DATE: []

SCALE: []

SW400

American garage door supply inc.
1225 Industrial Park Dr. SE.
Bemidji, MN 56601
1-800-233-1487 Ph. (218) 751-6551 Fax

DATE: [] TIME: []

BY: []

CHECKED: []

APPROVED: []

Notes



800-233-1487



Fax: (218) 751-6551



Carwashdoors.com

AmericanTM garage door supply inc.



Our Experience Works for You!

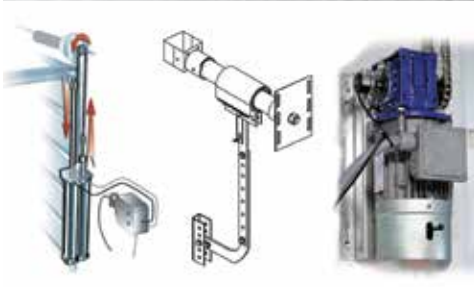

Products designed for excellent durability & performance in demanding or challenging applications.

- » Polycarbonate Doors
- » Full View Glass Doors
- » Insulated Washbay Doors
- » Stainless Garage Door Parts
- » Air Powered Operators
- » Specialty Electric Operators
- » Infrared Tube Heaters
- » Stainless Entry Doors